

**TCB<sup>®</sup>**

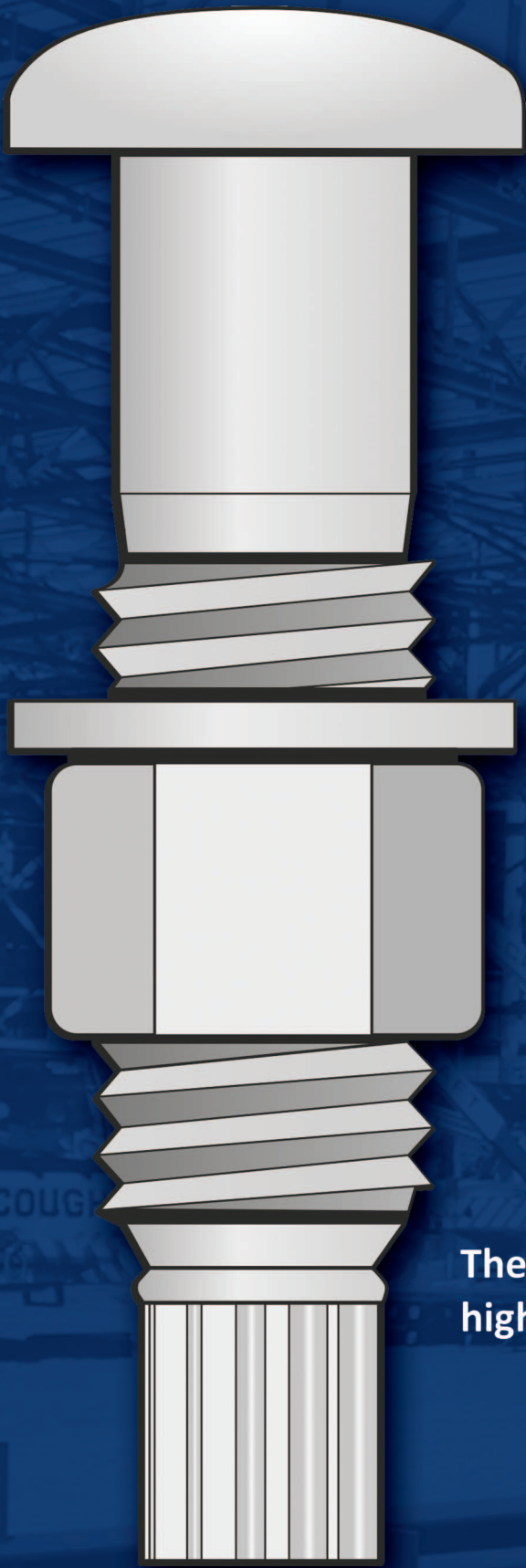

**The lowest cost method of properly installing  
high strength friction grip / preloaded bolts**

Tension Control Bolts are supplied with an environmentally friendly coating

 **Greenkote<sup>®</sup>**  
The ultimate anti-corrosion protection

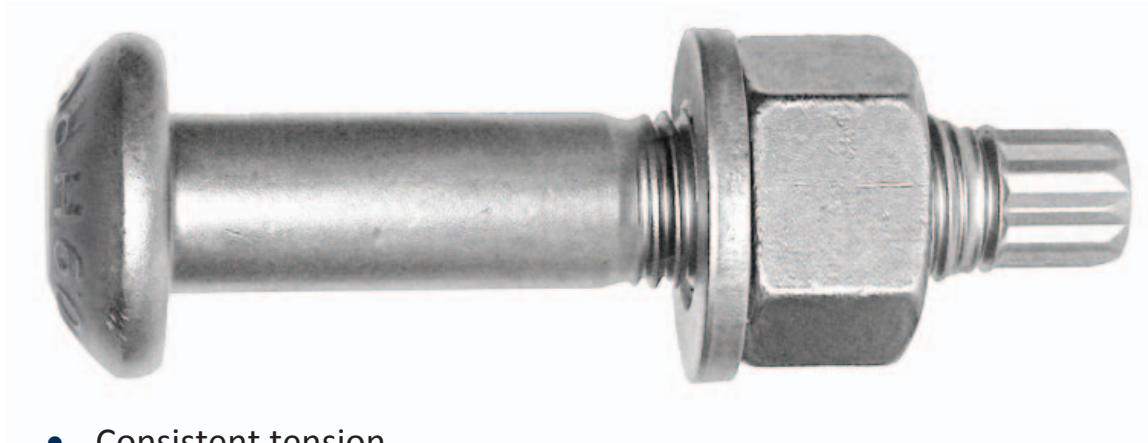

Technical

- Consistent tension
- Visual inspection
- Higher grade steel and increased pre-load facilitates the use of smaller diameter bolts
- TOCBs can be used in Shear and Tension
- No bolt relaxation since no torsional shear is induced during tightening
- Does not loosen with vibration – no locknut required
- Greenkote<sup>®</sup> metal finish has a very hard surface and does not crack or flake
- Greenkote<sup>®</sup> metal finish accepts paint without any preparation

Cost saving

- Quick, safe and easy to install
- One man installation
- Reduced tool maintenance
- One tool can install several diameters
- Tools do not self destruct so last many years
- Greenkote<sup>®</sup> metal finish requires no further treatment which means less time at site

Safety

- Non-impacting electric shear wrenches
- No risk of HAVS (hand-arm vibration syndrome)
- Reduced operator fatigue
- No air compressors with dangerous pipes & cables
- Low on-site noise – under HSE minimum levels
- No heavy calibrated torque wrenches required
- Ultra-light weight wrenches of varying shapes & sizes
- No acid required to etch bolts prior to painting due to special Greenkote<sup>®</sup> metal finish

# Installation procedure

## Before installation

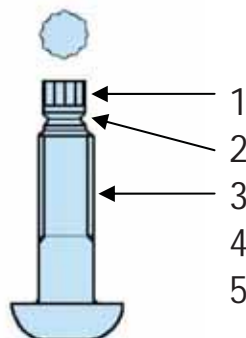

## During installation

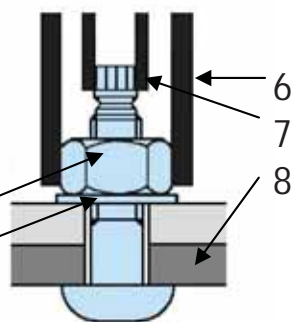

## After installation

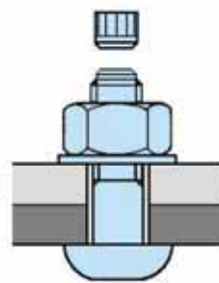

- 1 Spline
- 2 Break-neck
- 3 Thread
- 4 HRD Nut
- 5 Washer
- 6 Outer socket
- 7 Inner socket
- 8 Grip

1

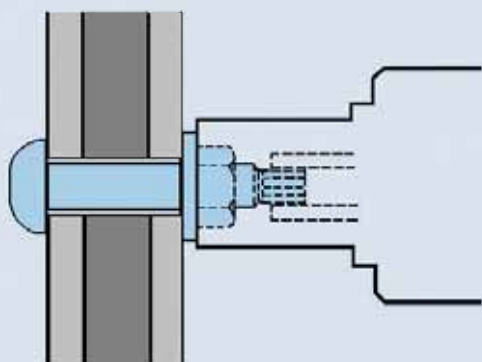

The inner socket of the shear wrench fits over the bolts spline while the outer socket fits over the nut.

2

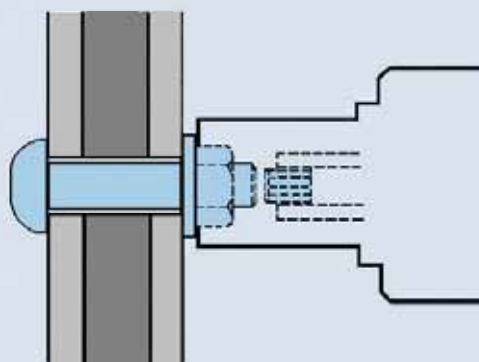

Press the trigger switch. The outer socket rotates clockwise and tightens the nut. When the correct preload is reached the outer socket stops rotating, the inner socket counter rotates and shears the spline off.

3

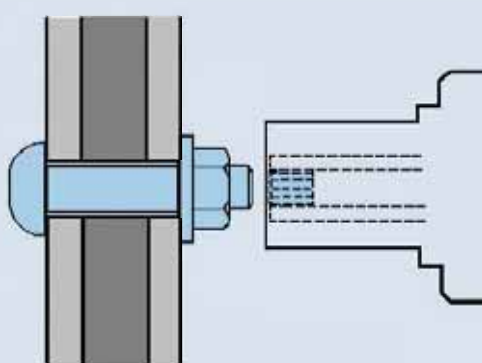

Stop the wrench and pull the outer socket off the nut. The spline is retained in the inner socket.

4

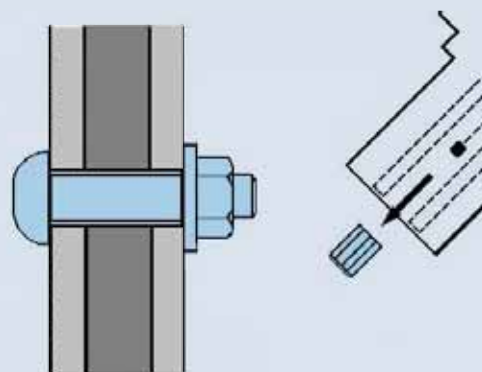

The wrench has a second trigger to eject the spline safely. The bolt is now properly installed with the correct tension.





Standard TCB<sup>®</sup> - used in a wide range of steelwork connections from bridge splice plates to beam-to-column connections, from stadia roof trusses to rail switches & crossings.



Smaller diameters used in the truck and trailer industry clearly demonstrate the anti vibration qualities of TCBS



TCB Stud<sup>®</sup> - Available in all diameters and produce the same performance characteristics as the standard TC Bolt. The left handed "head nut" allows the use of these studs in space saving compact joints.







TCB Shear Stud<sup>®</sup> - Ideal for repairing/strengthening old bridge decks involving steelwork which rely on pre-loaded bolts and a composite concrete deck requiring the need for shear studs. The TCB Shear Stud has dual performance.



Countersunk TCB<sup>®</sup> - Widely used in bridge decks and also column splices where space saving and/or aesthetics are critical.



Weathering Grade TCB<sup>®</sup> - M24 TCBs are available in weathering grade steel which meets the criteria of ASTM A325 Type 3



# Specifications, mechanical properties and standards for bolts

General requirements	EN 14399-1
Thread tolerance	6g
Thread standards	ISO 261, ISO 965-2
Mechanical properties: property class	10.9
Mechanical properties: standard	EN ISO 898-1
Dimensions and tolerances	EN 14399-10
Product marking	EN 14399-10

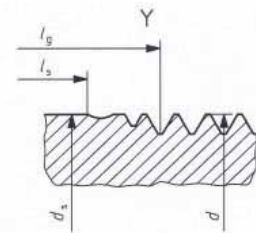
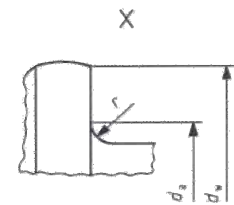

Nominal $\varnothing$	Stress area $\text{mm}^2$	Proof load min kN	Ultimate load kN	Hardness Rockwell	
				min	max
M12	84.3	70	87.7	32	39
M16	157	130	163		
M20	245	203	255		
M22	303	252	315		
M24	353	293	367		
M27	459	381	477		
M30	561	466	583		
M36	817	678	850		

## Dimensions of bolts<sup>a</sup>

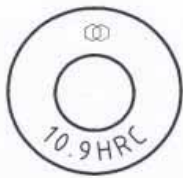

Bolt head marking



All dimensions in millimetres

Thread $d$		M12	M16	M20	M22	M24	M27	M30	M36
$p^b$		1.75	2	2.5	2.5	3	3	3.5	4
$b$ (ref)	$c$	30	38	46	50	54	60	66	78
	$d$	-	44	52	56	60	66	72	84
	$e$	-	-	65	69	73	79	85	97
$d_a$	max	15.2	19.2	24.4	26.4	28.4	32.4	35.4	42.4
$d_s$	max	12.7	16.7	20.84	22.84	24.84	27.84	30.84	37.00
	min	11.3	15.3	19.16	21.16	23.16	26.16	29.16	35.00
$d_k$	min	21	27	34	38.5	43	48	52	66
$d_w$	min	20	26	33	37	41	46	50	61
$k$	nom	8	10	13	14	15	17	19	23
	max	8.8	10.8	13.9	14.9	15.9	17.9	20.0	24.0
	min	7.2	9.2	12.1	13.1	14.1	16.1	18.0	22.0
$r$	min	1.2	1.2	1.5	1.5	1.5	2.0	2.0	2.0
$R$	nom	18	20	22	23	25	27	30	36
$F1$	min	11	13	15	15.5	16	19	21	25
$F2$	max	16	18	20	21	21.5	24	26	31
$U a$	Incomplete thread $u \leq 2 p$								

$a$  – the dimensions apply before coating

$b$  –  $p$  is the pitch of thread

$c$  – for lengths  $l_{nom} \leq 125\text{mm}$

$d$  – for lengths  $125\text{mm} < l_{nom} \leq 200\text{mm}$

$e$  – for lengths  $l_{nom} > 200\text{mm}$

Note –  $l_{g\max} = l_{nom} - b$ ,  $l_{s\min} = l_{g\max} - 5 p$

Note – when  $l_{s\min}$  as calculated by the formula in  $f$  is less than  $0.5d$  then its value shall be  $0.5d$  and  $l_{g\max} = l_{s\min} + 3p$



# Specifications, mechanical properties and standards for nuts

General requirements	EN 14399-1
Thread tolerance	6H pre-coating + 0.3mm
Thread standards	ISO 261, ISO 965-2
Mechanical properties; property class	10
Mechanical properties; standard	EN 20898-2

## Proof load value and hardness of nuts

Thread $d$	Nominal stress area of standard test mandrel $\text{mm}^2$	Proof load kN HRD <sup>a</sup> Nuts (nuts with height $m = 1 d$ )	Vickers Hardness	
			Min	Max
M12	84.3	104.9	272	353
M16	157	195.5		
M20	245	305.0		
M22	303	377.2		
M24	353	439.5		
M27	459	571.5		
M30	561	698.4		
M36	817	1017.1		

<sup>a</sup> – the proof load values are based on the stress under proof load of 1,245 MPa

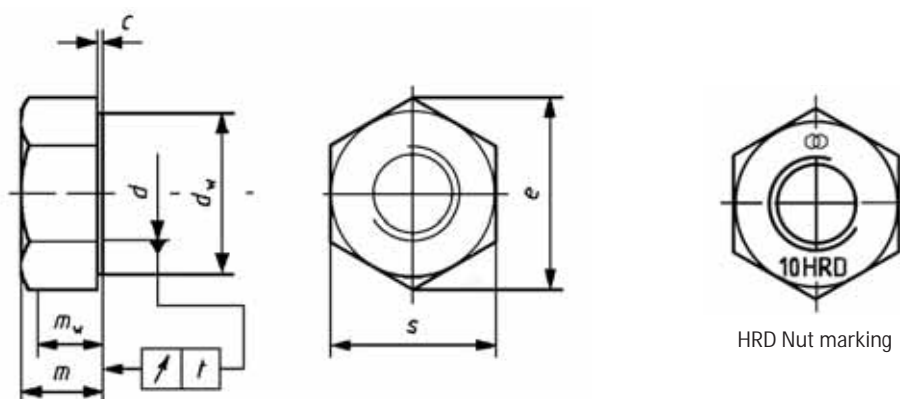

## Dimensions of HRD nuts <sup>a</sup>

Thread $d$		M12	M16	M20	M22	M24	M27	M30	M36
All dimensions in millimetres									
$p^b$		1.75	2	2.5	2.5	3	3	3.5	4
$d_a$	max	13	17.3	21.6	23.7	25.9	29.1	32.4	38.9
	min	12	16	20	22	24	27	30	36
$d_w$	max	<sup>c</sup>							
	min	20.1	24.9	29.5	33.3	38.0	42.8	46.6	55.9
$e$	min	23.91	29.56	35.03	39.55	45.20	50.85	55.37	66.44
$m$	max	12.35	16.35	20.65	22.65	24.65	27.65	30.65	36.65
	min	11.65	15.65	19.35	21.35	23.35	26.35	29.35	35.35
$m_w$	min	9.32	12.52	15.48	17.08	18.68	21.08	23.48	28.28
$c$	max	0.8	0.8	0.8	0.8	0.8	0.8	0.8	0.8
	min	0.4	0.4	0.4	0.4	0.4	0.4	0.4	0.4
$s$	max	22	27	32	36	41	46	50	60
	min	21.16	26.16	31	35	40	45	49	58.8
$t$		0.38	0.47	0.58	0.63	0.72	0.80	0.87	1.05

a – dimensions apply after Greenkote<sup>®</sup>

b –  $p$  is the pitch of thread

c –  $d_{w \max} = s_{\text{actual}}$

# Specifications, mechanical properties and standards for washers

General requirements	EN 14399-1	Nominal diameter	Vickers hardness (HV)	
Mechanical properties; standard	EN 14399-6		min	max
Dimensions and tolerances	EN 14399-6	M16 to M36	300	370

## Dimensions of washers <sup>a</sup>

All dimensions in millimetres

Nominal size	M12	M16	M20	M22	M24	M27	M30	M36	
$d_1$	min	13	17	21	23	25	28	31	37
	max	13.27	17.27	21.33	23.33	25.33	28.52	31.62	37.62
$d_2$	min	25.48	31.38	39.38	43.38	47.38	49.00	54.80	64.80
	max	26	32	40	44	48	50	56	66
$h$	nom	3	4	4	4	4	5	5	6
	min	2.7	3.7	3.7	3.7	3.7	4.4	4.4	5.4
	max	3.3	4.3	4.3	4.3	4.3	5.6	5.6	6.6
$e$	nom=min	0.50	0.75	0.75	0.75	0.75	1.00	1.00	1.25
	max	1.0	1.5	1.5	1.5	1.5	2.0	2.0	2.5
$c$	min	1.6	1.6	2.0	2.0	2.0	2.5	2.5	2.5
	max	1.9	1.9	2.5	2.5	2.5	3.0	3.0	3.0

<sup>a</sup> – dimensions apply before Greenkote<sup>®</sup>

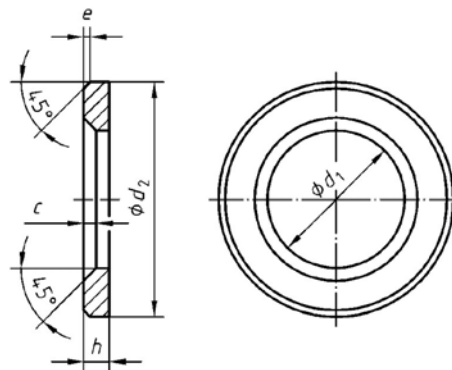

## Minimum specified preloads

Thread $d$	Nominal stress area of standard test mandrel $A_s$ mm <sup>2</sup>	$F_r$ min $0.7 \times f_{ub} \times A_s$ <sup>a</sup> kN	$F_r$ mean min $0.77 \times f_{ub} \times A_s$ <sup>a</sup> kN
		<i>Minimum individual value of bolt force at spline shear when tested in accordance with EN 14399-2 &amp; 10</i>	<i>Minimum mean value of bolt force at spline shear of 5 sets tested in accordance with EN 14399-2 &amp; 10</i>
M12	84.3	59.01	64.911
M16	157	109.9	120.89
M20	245	171.5	188.65
M22	303	212.1	233.31
M24	353	247.1	271.81
M27	459	321.3	353.43
M30	561	392.7	431.97
M36	817	571.9	629.09

<sup>a</sup>  $f_{ub}$  is the nominal tensile strength of the bolt ( $R_m$ , nom)

Whilst this information is provided in good faith, no person from Tension Control Bolts Ltd shall be under any responsibility or liability in respect of errors or information that is found to be incorrect or for any reliance the user may place on it.



Greenkote<sup>®</sup> is an innovative diffusion coating incorporating the very latest technology. The patented process is a Thermo-Chemical Surface Modification (TCSM) which can be applied to various metals, alloys, sintered ferrous base materials, grey iron and cast iron. Unlike conventional coatings, Greenkote<sup>®</sup> is totally environmentally friendly and does not produce any solid, liquid or gaseous toxic wastes. The process is also free of chrome, cadmium, acids, cyanides and chlorides.



Standard of coating: PM-1 (average 25 µm)  
 Coating Composition: Zn-Al polymetallic composition

**Advantages of Greenkote<sup>®</sup>:**

- Diffusion sacrificial corrosion resistance coating
- High degree of wear and abrasion resistance
- Salt spray resistance up to 1200 hours
- Long term corrosion protection up to 350°C (752°F)
- No hydrogen embrittlement
- Thickness uniformity ± 10% maximum
- Relatively low processing temperature
- Excellent preparation for painting, duplex coatings, adhesives and rubber mouldings\*

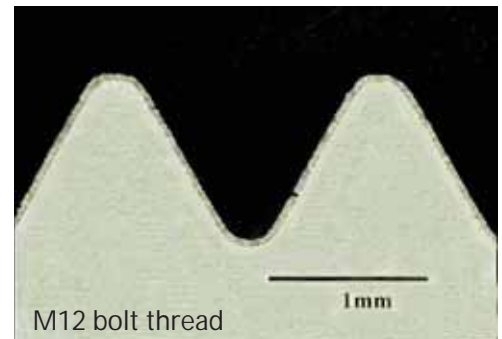

\*Excellent paint pull-off test results achieved with the following international paint manufacturers

International Paint Ltd Leigh's Paints	Ameron International Sigma Coatings	E. Wood Ltd Carboline Co
---	--	-----------------------------

### ASTM B117 Salt Spray Test 1 - Coating Loss

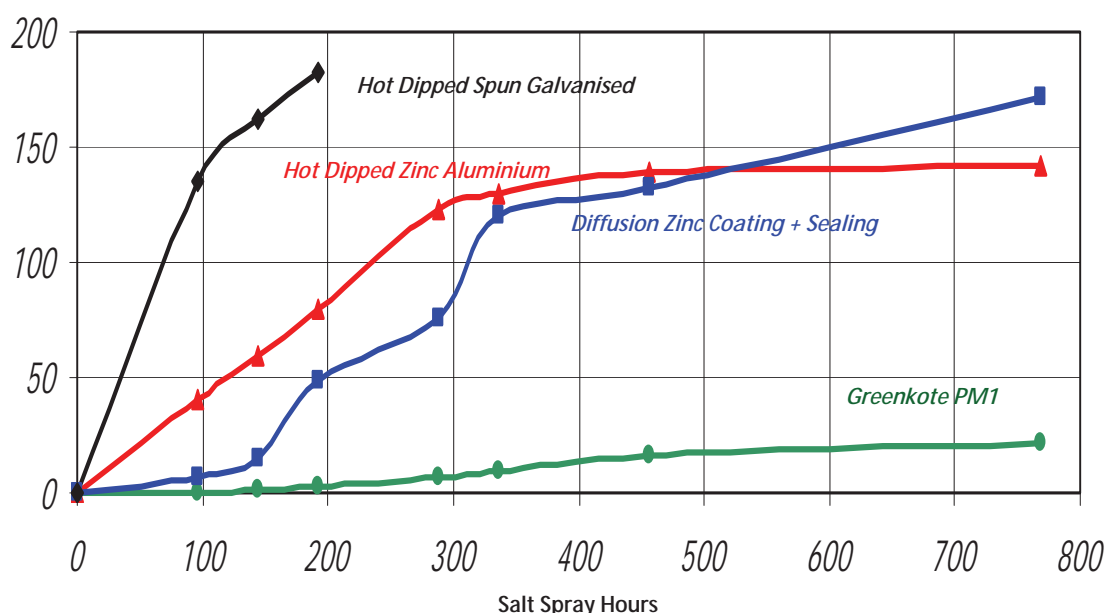

Failure is reached when the area of substrate corrosion exceeds 5% of the total sample area.

# Quality Assurance

Tension Control Bolts Ltd operates a quality management system in accordance with BS EN ISO 9001:2008 Certificate No. FS 86045

Other approvals include;



## Approved suppliers to:

ABB	Carillion	Morgan Sindall
Alfred McAlpine	Costain	Murphy Group
Alstom Power	C Spencer	Norwest Holst
Alstom Transport	eDF Energy	Samsung Engineering
Amec	Galliford Try	Sisk Group
Amey	Gammon Construction	Skanska
Babcock International Group	Interserve	Stobart Rail
Balfour Beatty	Kier Group	Tekfen
BAM Nuttall	Laing O'Rourke	Ustay
Bechtel	Mace	Vinci PLC
Bovis Lend Lease	May Gurney	VolkerWessels UK

## Specified by:

Aecom	Gifford	Roughan & O'Donovan
Arqiva	Halcrow	Royal Haskoning
Arup	Hyder Consulting	SKM
Atkins	Jacobs	Tony Gee & Partners
Black & Veatch	Mott Macdonald	URS Scott Wilson
Buro Happold	Mouchel	W A Fairhurst
Capita Symonds	O'Connor Sutton Cronin	Waterman Group
Cass Hayward	Parsons Brinkerhoff	WSP
Flint & Neill	Pell Frischmann	WYG



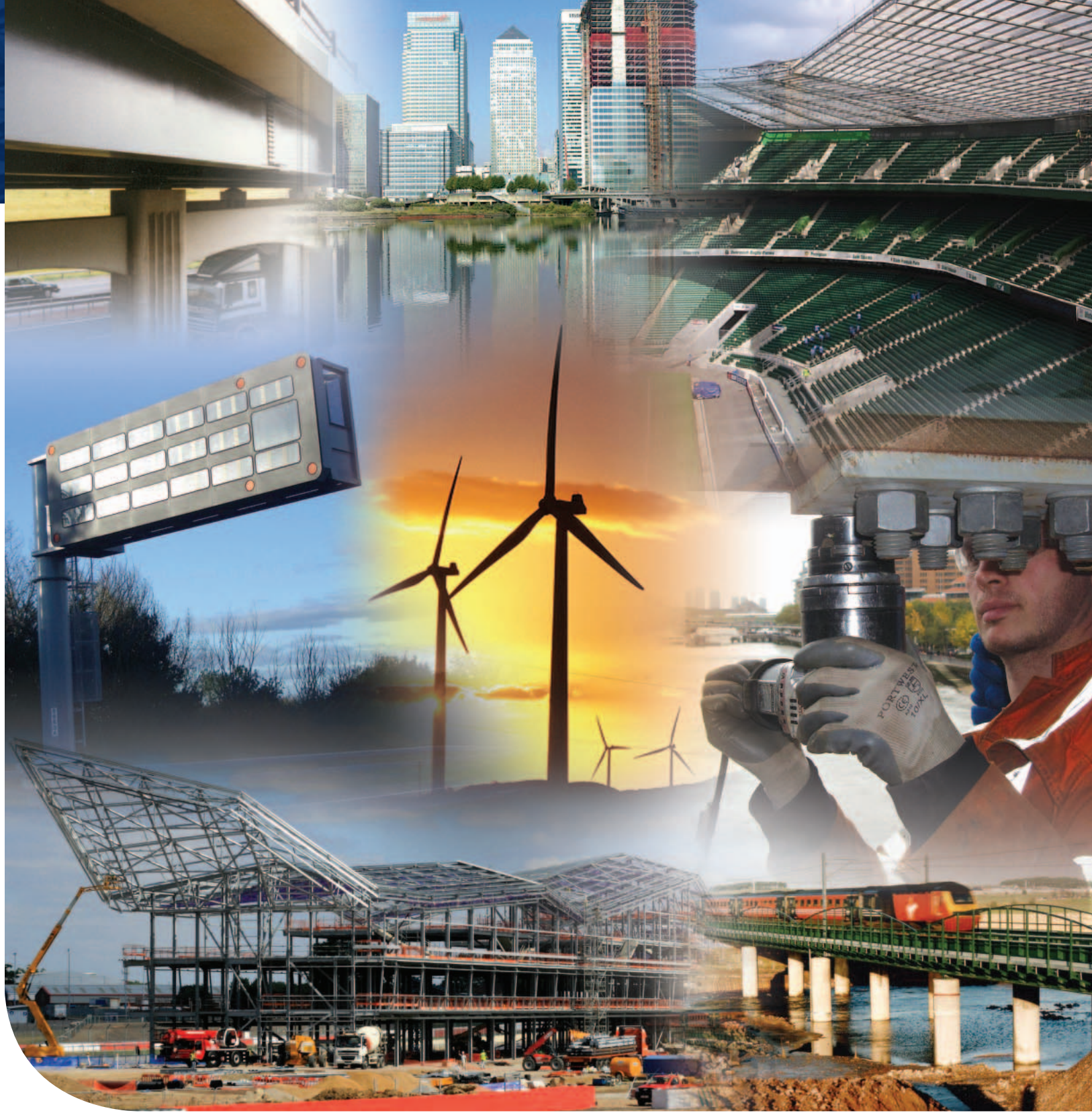





## Tension Control Bolts Limited

TCB House  
Clywedog Road South  
Wrexham Industrial Estate  
Wrexham LL13 9XS  
United Kingdom

Telephone: +44 (0)1978 661122

Fax: +44 (0)1978 661177

[info@tcbolts.com](mailto:info@tcbolts.com)

[www.tcbolts.com](http://www.tcbolts.com)



Certificate No. FS 86045